

## Wye Strainers

Fluidtrol Process Technologies, Inc. manufactures Wye Strainers to standards that exceed industry standards. These strainers are made for critical applications where high flow rates and high loading potential exists, while low pressure drops are desired.

Materials of Construction include PVC, CPVC, PP and PVDF lined FRP. This lamination construction combines the chemical resistance of the particular liner material (thermoplastic) and the structural strength of fiberglass. Wye Strainers are also offered in all-FRP construction. Resins can be used for high temperature and abrasive applications.

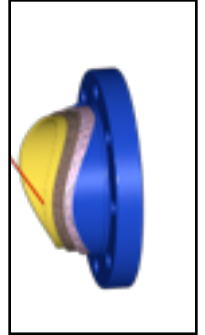

- EPDM lid gasket is standard, but Viton and Teflon are also options.
- Flanged lid with stainless bolts, nuts and washers are standard. T-Handle Design for easy lid removal is an option.
- Baskets are 1/4" perforated- made from same material as the strainer (FRP Wyes have PVDF Baskets). Other perms/materials are available.
- Pipe connections are Flanges. Threaded, socket, groove latch and True Union couplings are also available.
- Flanged or threaded blowdown ports are provided.
- Custom dimensions and designs are readily available.

WYE STRAINER DIMENSIONS				PERFORMANCE CRITERIA		
Flange Size	A	H	L	Basket Surface Area (in <sup>2</sup> )	Ratio- Basket Surface: Pipe	Flow Rate = 1 psid (Clean Basket)
2"	23	12	15.625	72.2	23	140 GPM
3"	28	18	21.375	72.2	10.2	140 GPM
4"	32	18	23	207.2	16.5	400 GPM
6"	39	20.875	28.25	384.3	13.6	790 GPM
8"	48	26	33.125	594.6	11.8	1150 GPM
10"	50	29.875	35	826.6	10.5	1600 GPM
12"	56	32.875	41.875	1130.4	10	2230 GPM
14"	60	41	45.25	1519.8	9.9	3000 GPM

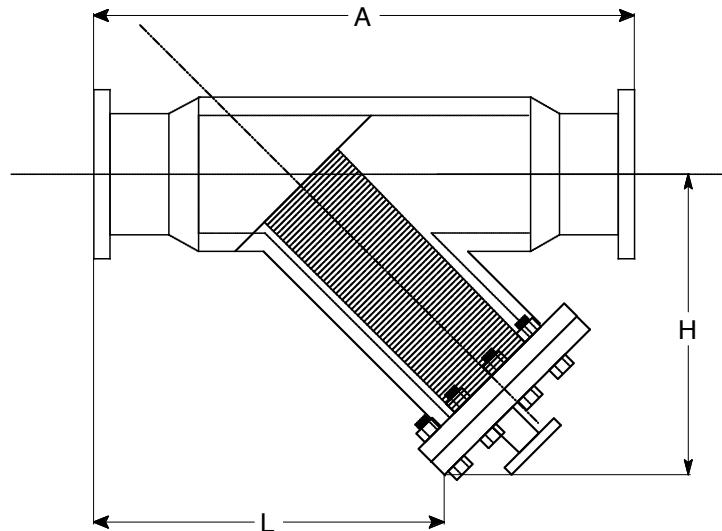

SPECIFICATION FOR FIBERGLASS REINFORCED PLASTIC  
*POLYPROPYLENE/FRP WYE STRAINERS*

1.) SCOPE

THIS SPECIFICATION COVERS REQUIREMENTS FOR SIMPLEX FRP/PP STRAINERS. WYE TYPES INTENDED FOR USE IN CHEMICAL PIPING SYSTEMS WHERE MAXIMUM RESISTANCE TO CORROSION , PRESSURE AND TEMPERATURE IS REQUIRED.

2.) STRAINER DESIGN

- 2.1 Strainer shall be flanged wye type.
- 2.2 Body configuration shall be in-line with Branch at 45 degrees.
- 2.3 Basket shall be polypropylene, Perforations 1/4" on 3/8" centers or as specified.
- 2.4 Minimum area ratio of pipe to basket shall be 10 to 1.
- 2.5 Cover shall be PP with 1/2" minimum flush tap- threaded or flanged.
- 2.6 Strainer shall be rated for 100 psi at 75 deg. F
- 2.7 Strainer design shall conform to ASME code for non-metallic pressure vessels.
- 2.8 Vendor shall supply min 5 years service history of applications in similar service.
- 2.9 Strainers shall be as manufactured by Fluidtrol Process Technologies, Inc.

3.) CONSTRUCTION

- 3.1 Strainer body shall be of dual laminate construction: PP with FRP over-wrap.
- 3.2 Strainer body shall be heat fused and back-welded prior to FRP over-wrap. All joints to be spark tested.
- 3.3 All flanges to ANSI 150 #.
- 3.4 Exterior protection is unsaturated polyester resin based high quality gel coat- 10 mils min.
- 3.5 All welding to be performed by craftsman qualified and certified to ASTM C-1147

4.0) STANDARDS

- 4.1 All products shall conform to or exceed the specifications as set forth in the following standards:

Cell Class PP0110-A2-1510 /ASTM D4101, Cell Class PP0110-M30-A10120 ASTM-2467 & ASTM -2657

