

GS SERIES - DUAL LAMINATE BASKET STRAINER

MAX PRESSURE RATING: 50-150 PSI
MAX TEMP: 140-280 F
SERVICE FLUID: CORROSIVE

The Fluidtrol GS series is a non-metallic housing inline basket strainer, engineered for corrosive industrial systems.

Wetted housing surfaces are comprised of a plastic liner made of PVC, CPVC, PP, or PVDF. The structural reinforcement is made of corrosion resistant FRP coated with a UV inhibited layer of protection. This dual laminate construction offers high corrosion resistance along with the structural integrity to last a project lifespan of 15-20 years.

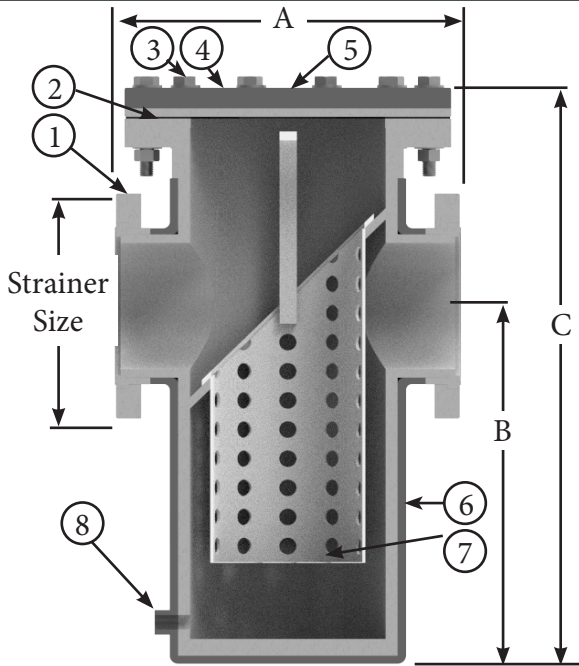

The standard strainer basket material matches the liner of the strainer housing, and has 1/4" perforations. Several options exist for clients requiring a different filtration level or material of construction as shown on page 2.

Item	Part	Material
1	Flange	Liner Plastic
2	Gasket	EPDM STANDARD
3	Fastener	SS316 STANDARD
4	Cover	Liner Plastic / FRP
5	Vent	Liner Plastic
6	Body	Liner Plastic / FRP
7	Basket	1/4" Perf Liner Plastic
8	Drain	Liner Plastic

GS PVC	GS CPVC	GS PP	GS PVDF	Strainer Size	Face to Face (inch) A	Center Line (inch) B	Height (inch) C	Aprox. Weight (lbs)	Basket Area / Inlet Area
GS111002031	GS122002031	GS133002031	GS144002031	2	13	10 1/2	19 1/2	50	18.8
GS111003031	GS122003031	GS133003031	GS144003031	3	13	10 1/2	19 1/2	52	15.6
GS111004031	GS122004031	GS133004031	GS144004031	4	14 1/2	11 5/8	22	66	17.1
GS111005031	GS122005031	GS133005031	GS144005031	5	18	16	26 1/2	100	12.6
GS111006031	GS122006031	GS133006031	GS144006031	6	18	16	26 1/2	102	12.6
GS111008031	GS122008031	GS133008031	GS144008031	8	20	21 1/2	34 1/2	150	11.3
GS111010031	GS122010031	GS133010031	GS144010031	10	22	23	37 1/2	182	10.2
GS111012031	GS122012031	GS133012031	GS144012031	12	27 1/2	31 5/8	46 3/4	280	10.1
GS111014031	GS122014031	GS133014031	GS144014031	14	35	32 1/2	49	370	13.0

Three different lid fasteners are available and described on page 3.
 Contact Fluidtrol if custom configurations or dimensions are required. Most custom work is 20% extra.



Plastic Liner	Max Pressure Rating *				Chemical Compatibility				
	Max Temperature	T-handle	Swing Bolt	Traditional Bolt	Most acids, alkalis, salt water	polar solvents, ketones	chlorinated hydrocarbons	aromatics	oxidizing acids
PVC	140 F	50 psi	100 psi	150 psi	Good	NR	Poor	NR	
CPVC	180 F	50 psi	100 psi	150 psi	Good	NR	Poor	NR	
PP	180 F	50 psi	100 psi	100 psi	Good	Good	NR	NR	NR
PVDF	250 F	50 psi	85 psi	85 psi	Good	Fair	Good	Good	Good

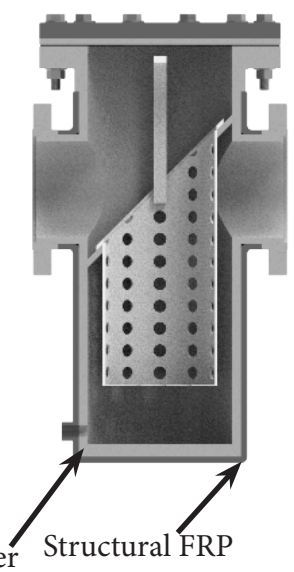

All GS series strainers have a certification letter available for compliance to the American Iron and Steel requirement as mandated in EPA's State Revolving Fund Programs.

NR - not recommended
 * The pressure rating derates on the operating temperature.

Plastic Liner Structural FRP

Baskets



The standard basket will be the same material as the plastic liner with 1/4 perforations. Select your basket by first determining the opening size. Next determine the material most suitable for your fluid. SS316 has the best availability. AL6XN is great for salt water. Hastelloy C276 and Monel are suitable for many fluids and a good option when mesh liners are required. PVC fairs well upto 140 deg F, PP and CPVC 180 deg F, and PVDF 250 deg F.

Perf /Mesh	Opening (mircron)	Effective Open Area						Hastelloy C276 / Monel	
			PVC	CPVC	PVDF	PP	SS316	AL6XN	
1/4" Perf	6350	40%	\$	\$	\$	\$	\$	\$\$	\$\$\$
3/16" Perf	4762	51%						\$	
5/32" Perf	3968	63%						\$	
1/8" Perf	3175	40%	\$	\$	\$	\$	\$		\$\$\$
20 mesh	841	21%	ETFE mesh liner is available for mesh sizes 20,40 and 60				\$\$		\$\$\$\$
40 mesh	400	20%					\$\$		\$\$\$\$
60 mesh	250	15%					\$\$		\$\$\$\$
80 mesh	177	17%					\$\$		\$\$\$\$
100 mesh	149	19%	PVDF mesh liner available				\$\$\$		

Other options available, Open area for mesh is estimate



WWW.FLUIDTROL.COM 888-551-0511
 FLUIDTROL PROCESS TECHNOLOGIES, INC.
 3460 STANWOOD BLVD
 HUNTSVILLE, AL 35811



Operators prefer basket strainers because they are easier to clean. The fasteners impact how much effort is required to clean the strainer. Below are some options to help optimize the strainer for your operation.



T-Handle
Limited to 50 psi
Fastest basket change

Fluidtrol's SS316 T-Handle/Swing Latch Assembly is the highest quality, most durable easy-off strainer lid hardware system made for any non-metallic strainer. All components of this assembly are machined from solid stock. Threaded sections are 3/8-16 and quantity of fasteners supplied vary upon strainer housing size. Standard design pressure rating for strainers with this lid fastener type is 50 psi.



Can't Decide?
Call Fluidtrol
US Customer
Support



Swing Bolt
Limited to 100 psi
Faster basket change

Swing Bolt fasteners have a slotted body flange and slotted cover. The slots and swing bracket allows operators to quickly loosen bolts and swing bolts away. The washer and nut stay attached and avoids having to bend over to pick up dropped hardware. The swing bolts diameter corresponds to the ANSI Flange, which allows for a higher pressure than the T-handles. There will be SS316 brackets on the housing- so it is not the best choice for very corrosive environments.



Traditional Bolts
150 psi
Most Corrosive Resistant

Traditional bolting uses an ANSI B16.5 Class 150 Blind Flange, and standard bolts. The FRP lids are much lighter than their metallic counterparts. Traditional bolting material options include SS304, SS316, and PTFE Coated Carbon Steel. This is a good choice for corrosive external (atmospheric) environments- or high pressure applications. Fastners are completely replacable.

