

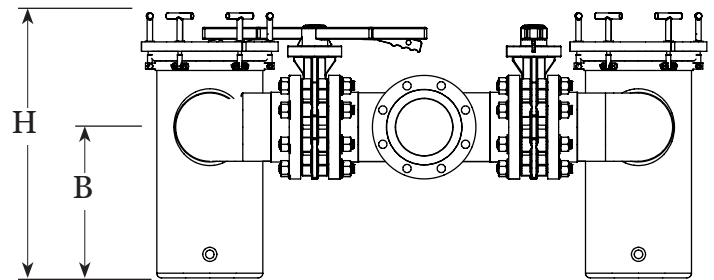

**PRESSURE RATING: 75 PSI
MAX TEMP: 140 F
SERVICE FLUID: MILD
CORROSIVE**

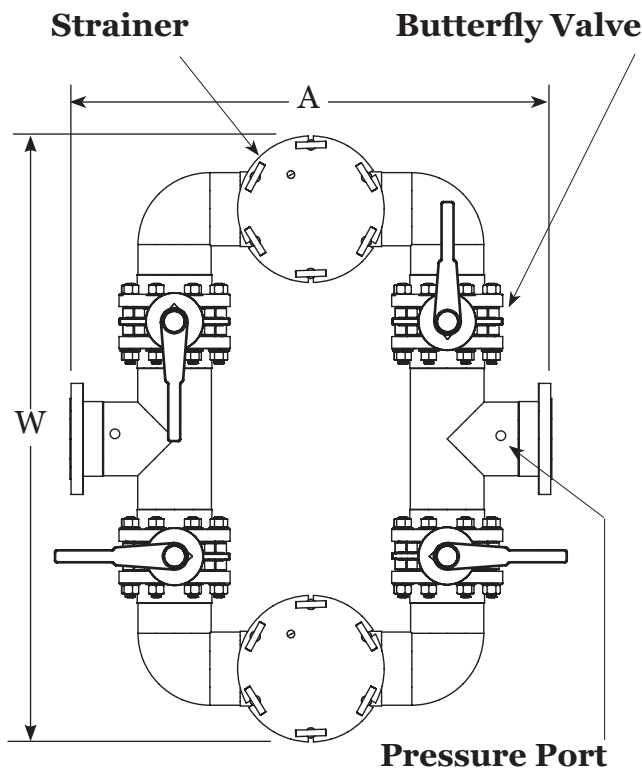

Duplex strainers are a good choice for critical systems for which flow interruption is prohibited. A properly designed composite duplex strainer assembly will allow full flow through one strainer, while the other is isolated and in standby with a clean basket in place. Monitoring the pressure drop via optional pressure taps on inlet/outlet manifold allows for easy identification of when basket becomes fouled and changeover is required.



PN	Strainer Size	Face to Face (inch) A	Center Line (inch) B	Width (inch) W	Height (inch) H
GX216102031	2	21 1/4	10 5/8	25 5/8	21 1/4
GX216103031	3	29 3/16	10 5/8	37 1/8	21 1/4
GX216104031	4	35 9/16	11 1/4	45 1/8	23 1/4
GX216105031	5	47 1/2	16 1/4	60 1/8	28 3/8
GX216106031	6	47 1/2	16 1/4	60 1/2	28 3/8
GX216108031	8	60 1/16	21 3/4	76 1/2	36 3/8
GX216110031	10	73 3/16	23 1/4	94 3/8	40 3/8
GX216112031	12	87 3/16	31 7/8	113 1/8	48 7/8
GX216114031	14	94 3/16	33	121	50 5/8

Rev. 11/30/23





SPC-FRP-005: SPECIFICATION FOR MOLDED FIBERGLASS REINFORCED PLASTIC (FRP) BASKET STRAINERS MADE FOR INDUSTRIAL WATER SYSTEMS- GX DUPLEX SERIES

1. SCOPE

The molded fiberglass reinforced plastic basket strainer shall be designed for the suction or discharge side of water and chemical systems. These strainers are designed for easy operation, assuming maintenance personnel have limited training and minimal tools to clean the basket. Baskets are designed to remove all foreign objects larger than basket perforation size.

2. DESIGN REQUIREMENTS

2.1. Configuration

- 2.1.1. Strainer type shall be flanged basket
- 2.1.2. Effluent shall be in-line with the influent
- 2.1.3. Height, drain port, basket size, and face-face dimensions shall be interchangeable with Fluidtrol GS series design

2.2. Flanges

- 2.2.1. Flanges shall allow easy installation into piping system by limiting rotational nozzle stress and flange bolt hole misalignments
 - 2.2.1.1. Flanges 12" and smaller shall be ANSI 150# Van Stone type- PVC SCH80.
 - 2.2.1.2. Flanges 14" and larger shall be FRP or fabricated- dual laminate
- 2.2.2. Flange material shall be PVC Cell Class 23447-B ASTM D-1784

2.3. Basket

- 2.3.1. Basket material shall be 316 Stainless Steel- or as specified.
- 2.3.2. Basket perforation shall be 1/8" on 3/16" centers- or as specified.
- 2.3.3. Basket shall have handle welded to body, capable of holding 50lbs of debris
- 2.3.4. Basket shall be able to withstand 15 psi pressure drop across the perforated wall
- 2.3.5. Basket open area shall be a minimum of 4 times greater than influent cross-section area

2.4. Basket Maintenance

- 2.4.1. No tools shall be required to remove the lid
- 2.4.2. The lid shall be molded FRP with a minimum thickness of 1" and flexural strength greater than 15,000 psi
- 2.4.3. Lid attachment shall be with 316 Stainless Steel Tee Handles / Swing Bolts
- 2.4.4. Gasket grooves shall be in the strainer body to prevent accidental misplacement
- 2.4.5. Basket shall self-center and remove in one simple motion
- 2.4.6. Basket shall be suspended to ensure positive seal at the basket flange
- 2.4.7. Vent plugs shall allow for gas removal without lid removal
- 2.4.8. Drain plugs shall be minimum 1 inch off floor to prevent plugging from debris

2.5. Duplex Operation

- 2.5.1. Two strainers shall be included, each capable of handling the system flowrate.
- 2.5.2. Butterfly valves shall be used to allow the strainer to be isolated and cleaned while operating the other strainer.
- 2.5.3. All elbows, tees, flanges, valves shall be made of SCH 80 PVC or better.
- 2.5.4. Bolting for flanges, tees, and valves shall be SS 304 or better.

2.6. Operating Conditions

- 2.6.1. Normal operating temperature is 75 deg F.
- 2.6.2. Maximum fluid temperature shall be 140 deg F with reduced pressure rating.
- 2.6.3. Maximum operating pressure is 75 psi with no surge.
- 2.6.4. Maximum suction pressure is 14 psig vacuum.

2.7. Pressure Rating

- 2.7.1. Hydrostatic testing of the strainer at 85 psig shall be conducted on every unit.

2.8. Materials of Construction

- 2.8.1. Gaskets shall be EPDM or Viton
- 2.8.2. Shell shall be FRP with high grade, corrosive resistant vinyl ester resin matrix
- 2.8.3. Strainer shall be constructed from components certified to NSF/ANSI 61
- 2.8.4. Exterior shall have UV protective inhibitors to maximize service life
- 2.8.5. Flanges shall be PVC Cell class 23447-B, ASTM D-1784

3. CONSTRUCTION

- 3.1. Manufacturer shall have minimum five year service history in industry
- 3.2. Manufacturer shall maintain as-built dimensions of each strainer
- 3.3. Manufacturer shall be ISO 9001:2015 Certified
- 3.4. Manufacturer shall supply minimum one year warranty on lids, baskets, and gaskets to cover defect in material or workmanship
- 3.5. Manufacturer shall supply minimum five year warranty on FRP shell to cover defect in material or workmanship
- 3.6. Approved manufacturer
 - 3.6.1. Fluidtrol Process Technologies, Inc. www.fluidtrol.com