

Fluidtrol Aquatic Products

Deep Bed Sand Filters

Owner and Operation Manual



This manual covers the following product numbers:

FPT-DBF42V72D



Certified to
NSF/ANSI/CAN 50



Table of Contents

Table of Contents

Table of Contents.....	2
Table of Revisions.....	3
Principles of Filtration.....	4
Backwashing.....	4
Filter Media.....	4
Rinsing.....	5
Installation, Assembly, and Startup.....	5
Receipt Inspection of Parts.....	5
Receipt Inspection of Filter Media.....	6
Inspect Internals.....	6
Site Preparation.....	6
Anchoring.....	6
Install Piping.....	6
Install media.....	7
Filling the Filter with Water.....	7
Initial Pressure Test and Sealing.....	7
Initial Rinse and Pressure Recording.....	8
Initial Backwashing.....	8
Filter Operation.....	8
Filter Mode.....	8
Backwash Mode.....	10
Maintenance.....	11
Backwash Schedule.....	11
Inspection Schedule.....	11
Filter Draining.....	11
Accessing Internals through Manway Port.....	11
Removal of Filter Media.....	11
Ordering Replacement Parts.....	12
Parts Lists.....	12
Pressure Drop Curve.....	12

Table of Revisions

Revision		Description
Draft	12/5/2018	Issued for development and NSF Review
0	12/10/2019	Incorporated NSF auditor comments
1	1/7/2020	Removed the FPT-DBF42V96D from the product list.
2	5/13/2020	Updated Influent Pictures, Pressure Drop Curve, and Parts List
3	5/19/2021	Revised Pressure Drop Curve
4	7/27/2021	Added NSF logo

Principles of Filtration

The high rate sand filter is designed to clean water by retaining solids in the sand media as the fluid flows through the sand bed. Dirty water enters the influent and is distributed through the spray nozzles. The arrangement of spray nozzles ensures distribution of water across the entire cross section of the filter tank. Dirty water passes into the sand media with uniform velocity profile and unwanted particulate becomes trapped in the sand media. Clean water escapes in laterals below the sand media and flows out the effluent piping (figure 1). The laterals sit in a gravel bed that help distribute flow to all the laterals better than the sand media alone. Each lateral has several slits that prevent sand smaller than 0.01" from exiting the filter.

Backwashing

As the filter traps more particulate, the pressure drop across the bed rises. Generally, when the pressure differential increases by 7 psi, the filter needs to be cleaned by back washing. During backwashing the flow is reversed to fluidize the bed (figure 2). The upward velocity lifts unwanted particulate from the sand bed and flow through the influent piping. The sand bed will also expand between 20-60%. The difference between the terminal velocity for the unwanted particle and the sand media grain allows the filter to separate the unwanted particle from the sand bed. However, backwashing too fast can blow the sand too high, allowing it to escape into the backwash drain.

During backwashing, the heaviest filter media will fall to the bottom first. Overtime the smallest sand grains are on top, and the largest are on the bottom. This is not ideal for normal operation. To mitigate this issue, select sand designed for your application. Also minimize the amount of backwashing by stopping as soon as the water becomes clear in the backwash discharge.

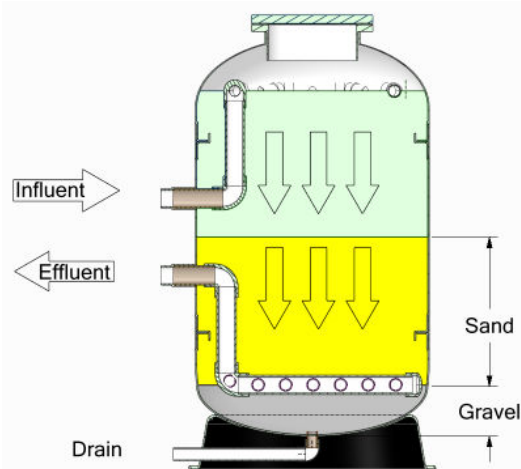

Figure 1 Normal Operation

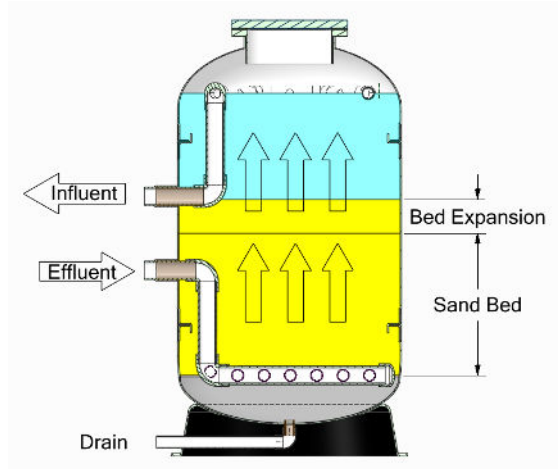

Figure 2 Backwashing Operation

Filter Media

The filter media is primarily sand that is supported by gravel. The gravel bed reduces the amount of sand bed expansion during backwash and improves flow into the laterals during normal operation. How much the filter bed expands depends on the filter media and the backwash flowrate. The selection of filter media and backwash flowrate can be customized to each application. The filter media, typically sand,

should be selected as the largest particle size that will trap your unwanted particles. Using sand that is smaller than required will cause problems during backwashing, and increase the pressure drop during operation. This manual assumes a typical pool installation.

Rinsing

Rinsing is running clean water through the influent and allowing it to drain either through the effluent piping or the bottom drain. The purpose of rinsing is to wash any dust from new filter media, and reset the sand bed.

Installation, Assembly, and Startup

Installation requires preparation, positioning the filter, plumbing to the filter, and installing the media. To prepare for install, first inspect the parts and media. Then prepare the site and position the filter. When all fit ups are complete, plumb the filter and load the filter media. Lastly complete the startup procedure.

Receipt Inspection of Parts

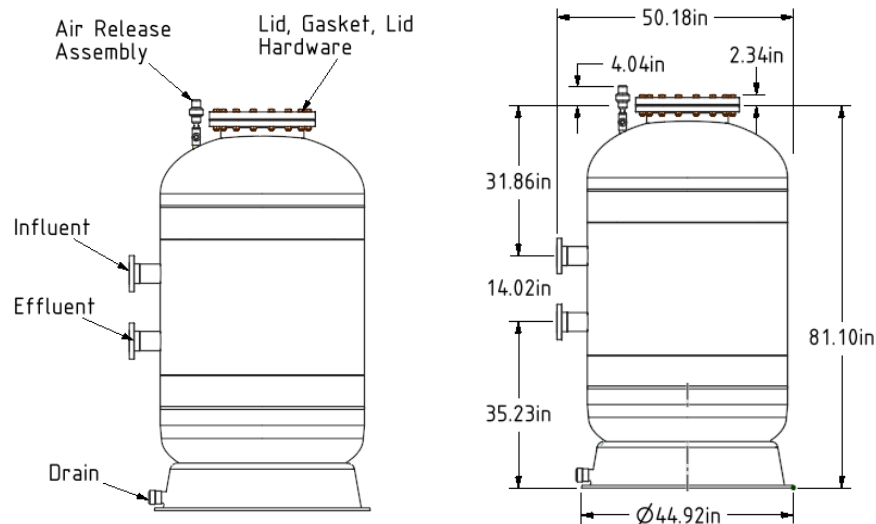

Verify your filter lid, bolting hardware, and gasket are installed. The remaining components come preassembled, and disassembly is not advised.

Component	Qty
Filter	1
Lid	1
Lid Gasket	1
Lid Bolts	16
Lid Nuts	16
Lid Washers	32
Air Release Assembly	1

Receipt Inspection of Filter Media

Verify the filter media is as specified on the site install work orders. The table below lists the typical sand and gravel selection. Both components should come from a filtration supplier because non-pool filter sand and gravel will reduce filter efficiency. All filter media should come pre-washed and free of dust.

Item	Sand	Gravel
Name	No. 20 Standard Silica	Gravel
Uniformity Coefficient	Max 1.75	NA
Minimum Diameter	0.018"	0.125"
Maximum Diameter	0.020"	0.250"

Inspect Internals

Inspect the internals to identify damage during shipping. If there are any obvious cracks or damage please contact Fluidtrol.

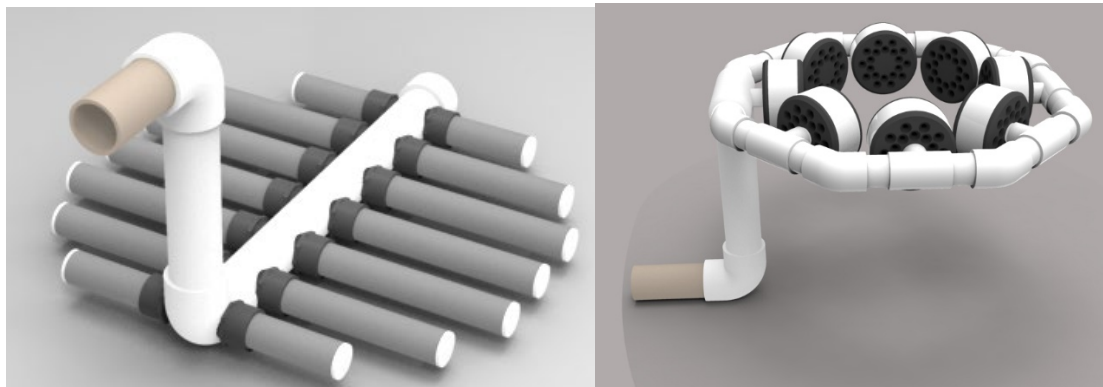

Site Preparation

Prior to plumbing the filter, verify the site selected has adequate floor space and height to access the lid, drains and any ports. The filter should sit on a concrete pad. Installing on sand or particle board could potentially erode if it becomes wet. The saddle on the filter can be drilled and anchored to the floor.

Verify the influent and effluent height off the floor and position the filter to allow for plumbing to these ports. Connect the drain to any piping or hose that diverts the water to the site drainage system. It is also ideal to have a temporary hose connected to the lid vent during startup.

Anchoring

Mark drill holes for the filter skirt into the concrete pad. If no design is specified by the site engineer, use 1/2" anchor bolts to attach to the concrete pad. Holes can be drilled anywhere on the skirt lip. Its advised to use water while drilling fiberglass to cool the drill bit.

Install Piping

Attach the appropriate slip on fitting to the influent and effluent if not preinstalled from Fluidtrol. Take care that any excess glue is removed and water tight seal is made. Ensure the tank influent is receiving water and the effluent is attached to the return. Verify the drain is plugged or valve turned off.

Install media

Gravel should be installed first and cover the laterals such that the effluent header is barely covered. Ensure the gravel is evenly distributed (flat). Sand should be added to no more than half of the vessel, which is between the side ports. Ensure the sand is within an inch of perfectly flat with no valleys, dunes, or channels.

Model	Sand ft ³	Gravel ft ³
FPT-DBF42V72D	21.4	5.5

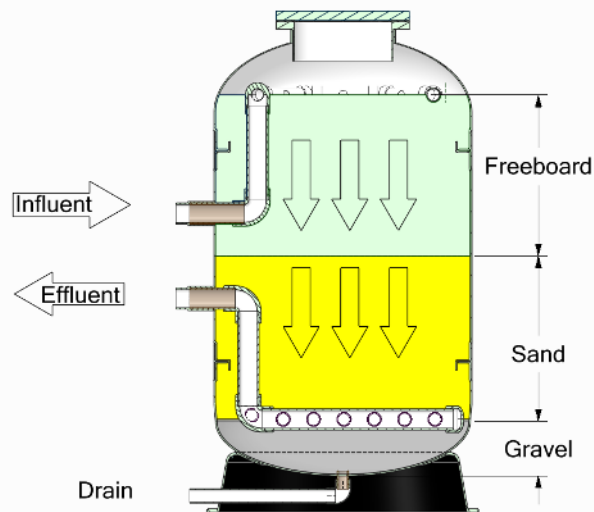

Filling the Filter with Water

Attach the lid, and hand tighten the bolts. The lid should compress the gasket around 5 ft-lb of torque. Overtightening will cause problems making the gasket seal or possibly crack the lid. Install the air vent valve and leave open. Water should be filled to the top, and air bled out from the lid vent.

Initial Pressure Test and Sealing

Once filled close the vent and verify the lid is sealed. Increase the pressure slowly. If a leak occurs at the lid, tighten each bolt slightly. Looking through the lid, verify there is no debris preventing sealing. A dark black ring should be seen where the wetted gasket has sealed to the lid. If sealing still has not occurred, depressurize and verify the flange was free of debris.

After the desired test pressure is achieved, verify all drains, inlets, outlets and ports are not leaking.

Initial Rinse and Pressure Recording

It is desirable to rinse the filter after pressure testing and allow the water to drain from the bottom for several minutes. This washes minor dust from the system and reduces the chances. Close the drain and flow water out the effluent. Record the pressure drop across the filter.

Model	Feed Flowrate (gpm)	DP No Media (psi)	DP w/ Typical Media (psi)	Actual DP (psi) (Block 1)
FPT-DBF42V72D	192	4	11	

Initial Backwashing

The filter should be backwashed prior to putting in service to record the actual DP during backwashing. During backwashing the bed is unstable and the pressure may fluctuate from the expected differential pressure. Backwash for no more than 5 minutes. To help future operators record the pressure range during the initial backwashing. Also record the time for clear discharge. During the initial backwash, there may be little to no debris in the discharge. The time for clear discharge will help future operators minimize undesirable bed stratification. After backwashing return the system to normal operation mode. Verify the sand has not channeled or distributed unevenly.

Model	Backwash Flowrate w/Typical Media (gpm)	Expected DP w/ Typical Media (psi)	Actual DP	Time for Clear Discharge
FPT-DBF42V72D	192	7-17		

Filter Operation

The filter can be operated in two different modes: filtration mode, and backwashing mode.

Filter Mode

The filter mode is the normal mode. Prior to startup check for air trapped at the lid. Also check to see the drain and vent is closed. Dirty water should enter the top and exit from the bottom. The sand should be level with less than 1" valleys and no channeling.

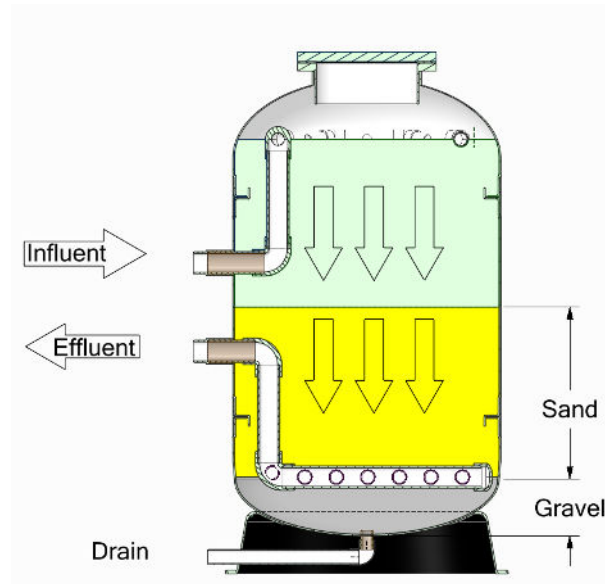

During normal operation the filter requires little maintenance. Periodically check for air trapped at the lid and an increase in differential pressure. An increase in differential pressure greater than 7 psi from the initial rinse DP, indicates the need for backwashing.

Model	Feed Flowrate (gpm)	DP w/ Typical Media (psi)	DP for Cleaning (psi)
FPT-DBF42V72D	192	9	16

Backwash Mode

Periodically the filter needs to be backwashed. To initiate backwash, stop the flow and valve incoming water to the effluent (bottom) port. Valve the influent (top) port to the waste stream. Increase the flow until you reach the backwash flowrate. Note the actual DP and time to see clear discharge. Backwashing should not last longer than 5 minutes and ideally stop immediately after you see clear discharge. Vent any air that may have been introduced during backwashing. Return the system to normal operation.

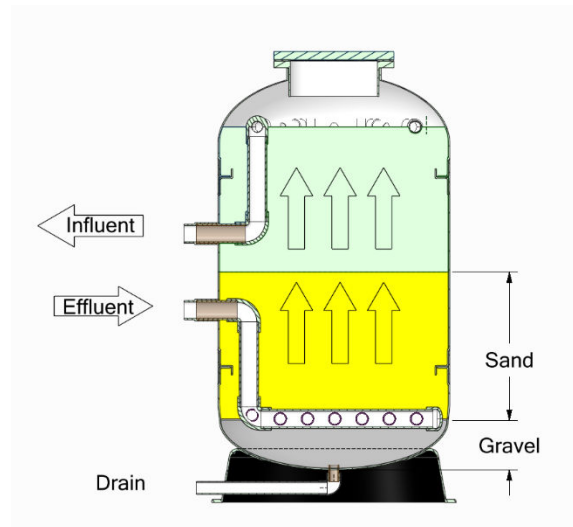

Model	Backwash Flowrate w/Typical Media (gpm)	Prewash DP (psi)	Postwash DP (psi)	Time for Clear Discharge
FPT-DBF42V72D	192			

Maintenance

Backwash Schedule

Backwash should occur only when the filter is dirty. This is typically a 7psi increase in differential pressure from the clean filter differential pressure. Backwashing too frequently will decrease filter performance.

Inspection Schedule

The filter needs to be inspected once a month for air buildup at the lid. Air will accumulate in the filter because of the slow-moving water. Venting trapped air will reduce safety risks and improve the ability to see the filter internals. The vent is located on the lid.

Inspect the differential pressure of the filter. An increase of 7 psi indicates a dirty filter.

Inspect the internals of the filter to verify the sand has not shifted or channeled.

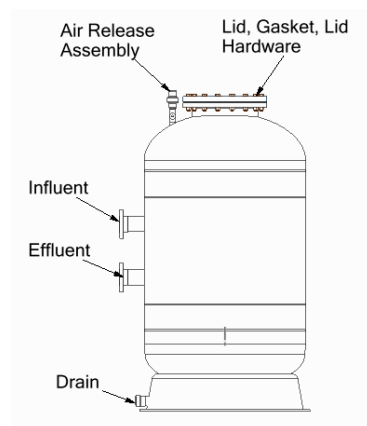

Filter Draining

Draining the filter is required sometimes for maintenance. To drain the filter, open the vent and the drain.

Accessing Internals through Manway Port

Accessing the internals can be accomplished by depressurizing and draining the filter, removing the lid, and entering the vessel. This should not be attempted alone. Prior to entering verify you have a battery-operated flashlight and rope to assist in exiting the filter. There should not be any obstructions to entering the filter. It is advised to use a rake to perform most of the required servicing without fully entering the filter.

Removal of Filter Media

Removal of the filter media can be accomplished by entering the filter and shoveling the media out of the filter. Care should be taken not to pry laterals off with the shovel tip.

Ordering Replacement Parts

Component	Qty	PN
Lid	1	FPT-BF1614-100
Lid Gasket	1	FPT-GSK1416
Lid Hardware Set	16	FPT-LHW0050-001
Air Release Assembly	1	FPT-ARA-001
Diffuser	8	FPT-DIF004
Lateral Short	4	FPT-EFF001
Lateral Med	4	FPT-EFF002
Lateral Long	6	FPT-EFF003

Parts Lists

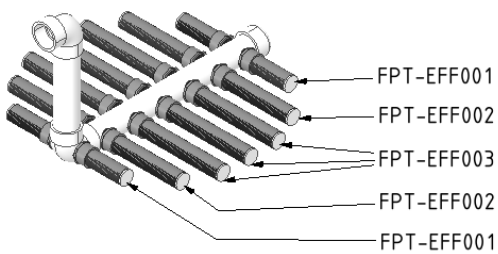
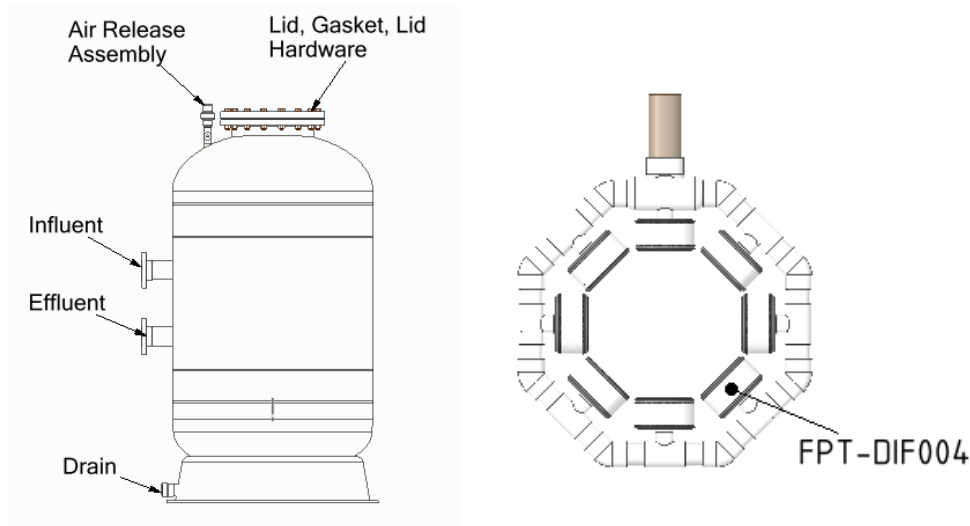

Pressure Drop Curve

